

Input Bias Offset
 Input Offset Current
 Offset Voltage

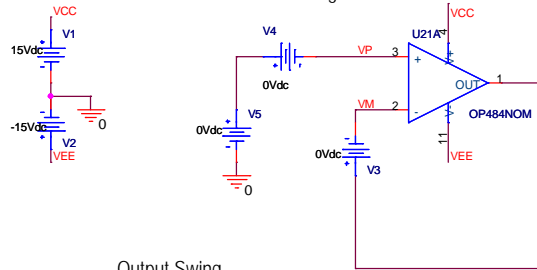

Output Swing

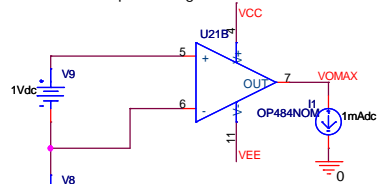

Offset Swing

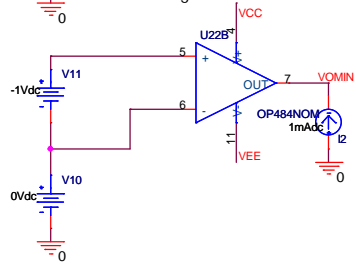

Slew Rate

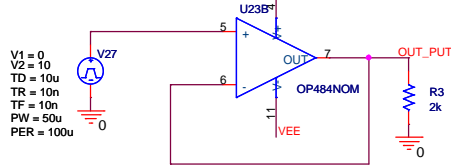

Output Short Circuit

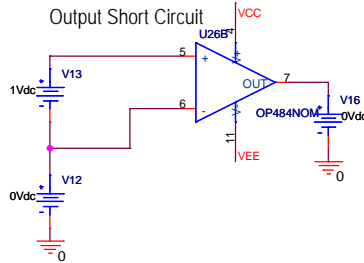

Output Short Circuit

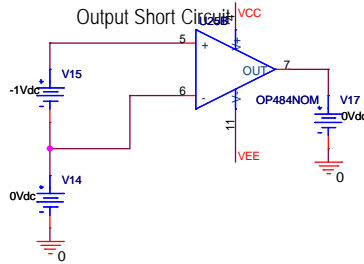

Power Supply Rejection Ratio

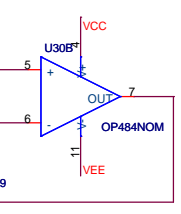
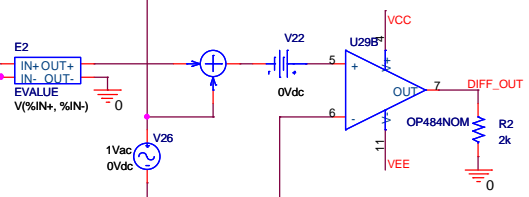
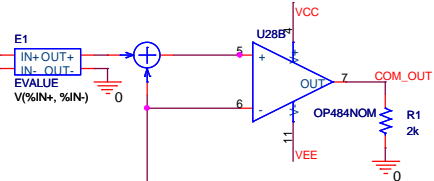
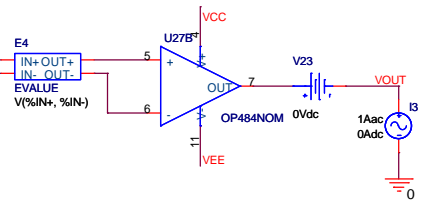
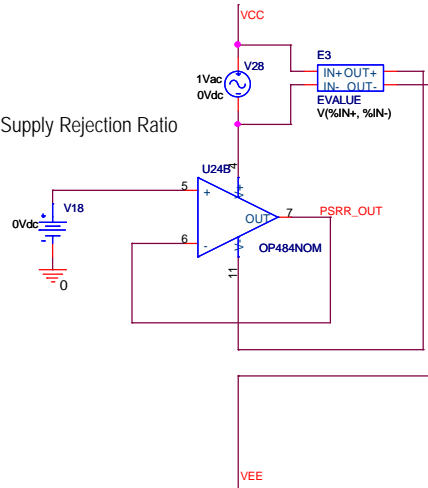

Common Mode Rejection
 Gain Bandwidth Product
 Excess Phase
 Open Loop Gain

Title		
OP484NOM_TEST		
Size	Document Number	Rev
B	<Doc>	<RevC>
Date:	Tuesday, January 18, 2005	Sheet 1 of 1